

120 BGF series

120X120X32mm

●General Specification / 一般規格

- Motor / DC brushless motor
- Material / Frame : plastic(94V-0)
Impeller : plastic(94V-0)
- Bearing / Ball bearing
- Weight / 180g
- 馬達 / 直流單向無刷馬達
- 材質 / 框：塑膠(94V-0)
葉：塑膠(94V-0)
- 軸承 / 滾珠軸承
- 重量 / 180克



●Specification / 詳細規格 * 軸承/bearing B: 雙滾珠/ball bearing F:FMB S: 含油承軸/sleeve bearing

Model 機型	Bearing 軸承	Voltage 電壓	Operating Voltage 操作電壓	Current 電流	Speed 轉速	Max. Air Flow 最大風量	Max. Static Pressure 最大風壓	Sound 噪音	P-Q P-Q曲線
Part No.	B / S / F	V	V	A	RPM	m ³ /min CFM	Pa In-H ₂ O	dBA	No.
BGE12032_12L	B	12	7.0~13.2	0.40	2100	0.70 24.6	139.4 0.56	45	①
BGE12032_12M	B	12	7.0~13.2	0.58	2500	0.82 28.8	206.7 0.83	47	②
BGE12032_12H	B	12	7.0~13.2	1.11	2800	0.91 32.1	263.9 1.06	49	③
BGE12032_12U	B	12	7.0~13.2	1.25	3100	1.06 37.5	321.2 1.29	52	④

● Drawing/ 圖面及出入風口

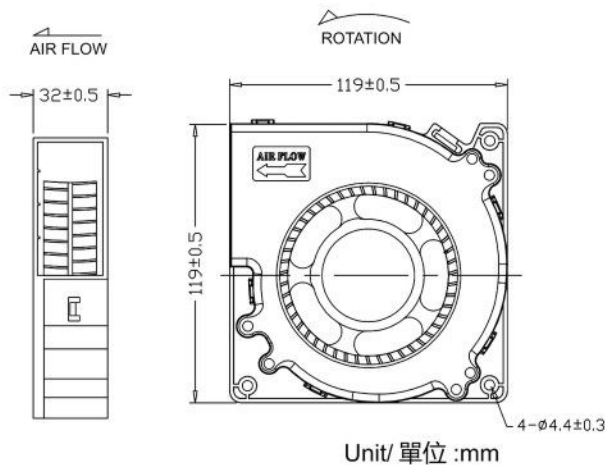

● Characteristic Curves/ 特性曲線

