

# 50

## AGC series

### 50X50X15mm

#### ●General Specification / 一般規格

- Motor / DC brushless motor
- Material / Frame : plastic(94V-0)  
Impeller : plastic(94V-0)
- Bearing / Ball bearing;FMB
- Weight / 38g
- 馬達 / 直流單向無刷馬達
- 材質 / 框：塑膠(94V-0)  
葉：塑膠(94V-0)
- 軸承 / 滾珠軸承;FMB
- 重量 / 38克



#### ●Specification / 詳細規格 \* 軸承/bearing B: 雙滾珠/ball bearing F:FMB S: 含油承軸/sleeve bearing

Model	Bearing	Voltage	Operating Vol.	Current	Speed	Max. Air Flow	Max. Static Pressure	Sound	Weight		
機型	軸承	電壓	操作電壓	電流	轉速	最大風量	最大風壓	噪音	重量		
P/N	B/S/F	V	V	A	RPM	m <sup>3</sup> /min	CFM	mm-H <sub>2</sub> O	In-H <sub>2</sub> O	dBA	g
AGC05015*12J	B/F	12	6.0~13.2	0.09	3600	0.30	10.51	2.37	0.09	20.65	38
AGC05015*12L	B/F	12	6.0~13.2	0.12	4200	0.34	12.17	3.17	0.12	23.29	38
AGC05015*12M	B/F	12	6.0~13.2	0.09	4800	0.37	13.13	3.72	0.15	25.88	38
AGC05015*12H	B/F	12	6.0~13.2	0.10	5400	0.43	15.26	4.68	0.18	28.88	38
AGC05015*12U	B/F	12	6.0~13.2	0.11	6000	0.48	16.84	5.71	0.22	31.09	38
AGC05015*24J	B/F	24	12.0~26.4	0.02	3600	0.30	10.51	2.37	0.09	20.65	38
AGC05015*24L	B/F	24	12.0~26.4	0.03	4200	0.34	12.17	3.17	0.12	23.29	38
AGC05015*24M	B/F	24	12.0~26.4	0.03	4800	0.37	13.13	3.72	0.15	25.88	38
AGC05015*24H	B/F	24	12.0~26.4	0.06	5400	0.43	15.26	4.68	0.18	28.88	38
AGC05015*24U	B/F	24	12.0~26.4	0.07	6000	0.48	16.84	5.71	0.22	31.09	38

#### ● Drawing & panel out-cuts/ 圖面及出入風口

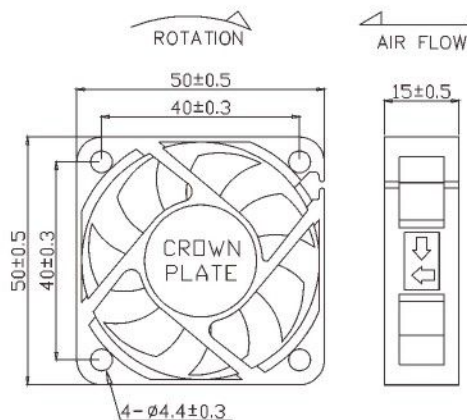

#### ● Characteristic Curves/ 特性曲線

